



UNIVERSITY OF CAMBRIDGE INTERNATIONAL EXAMINATIONS
General Certificate of Education Ordinary Level

CANDIDATE
NAME

CENTRE
NUMBER

--	--	--	--

CANDIDATE
NUMBER

--	--	--	--



SCIENCE

5124/02
5125/02

Paper 2 Physics

October/November 2008

1 hour 15 minutes

Additional Materials: Answer Booklet/Paper

READ THESE INSTRUCTIONS FIRST

If you have been given an Answer Booklet, follow the instructions on the front cover of the Booklet.
Write your Centre number, candidate number and name on all the work you hand in.
Write in dark blue or black pen.
You may use a soft pencil for any diagrams, graphs or rough working.
Do not use staples, paper clips, highlighters, glue or correction fluid.
DO NOT WRITE IN ANY BARCODES.

Section A

Answer **all** questions.
Write your answers in the spaces provided on the question paper.

Section B

Answer any **two** questions.
Write your answers on the lined paper provided and, if necessary, continue on separate answer paper.

At the end of the examination, fasten all your work securely together.
The number of marks is given in brackets [] at the end of each question or part question.

For Examiner's Use	
Section A	
Section B	/
Total	

This document consists of **12** printed pages and **4** lined pages.



Section A

Answer **all** the questions.

Write your answers in the spaces provided on the question paper.

- 1 Fig. 1.1 shows a spring that a student uses to find the weight of an object **X**.

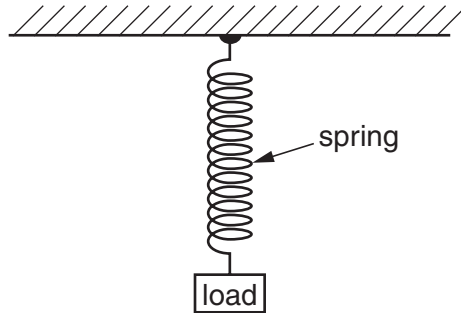

Fig. 1.1

She measures the length of the spring with no load and then with a 6.0 N weight attached. She then measures the length of the spring with object **X** attached. The spring returns to its unstretched length when each load is removed. The pupil's results are shown below.

length of spring with no load = 21.0 cm

length of spring with the 6.0 N weight = 33.0 cm

length of spring with the object **X** = 28.0 cm

Calculate the weight of object **X**.

weight = N [3]

- 2 Some powder of mass 30 g is poured into a measuring cylinder containing water. Fig. 2.1 shows the measuring cylinder before and after the powder is added.

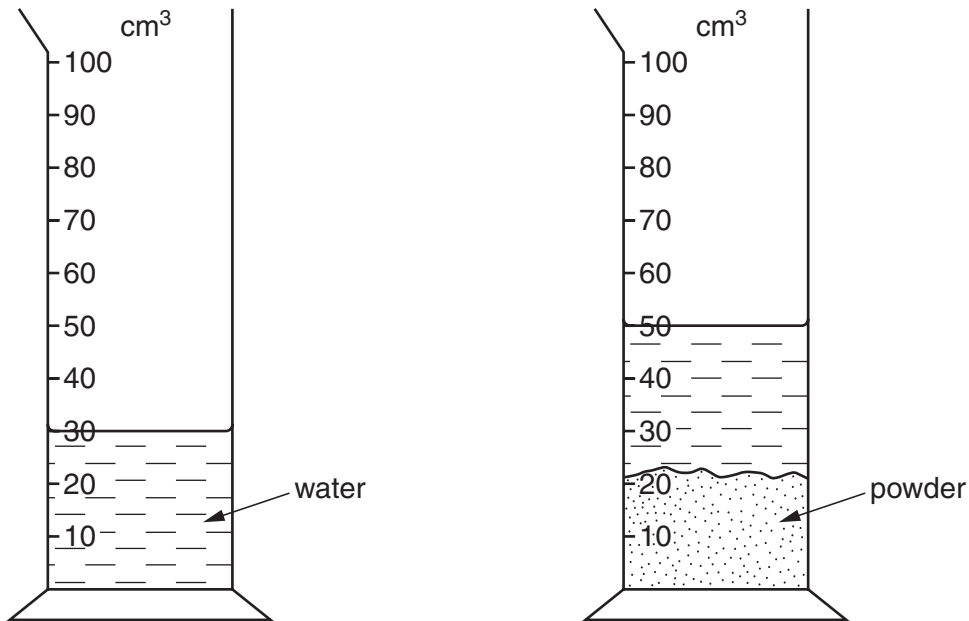

Fig. 2.1

The powder is insoluble in water and there are no air bubbles in the water. All volumes are measured in cm^3 .

Calculate the density of the powder.

density = g/cm^3 [3]

- 3 Fig. 3.1 shows the total forces acting forwards and backwards on a car at different times **X**, **Y** and **Z** during a journey.

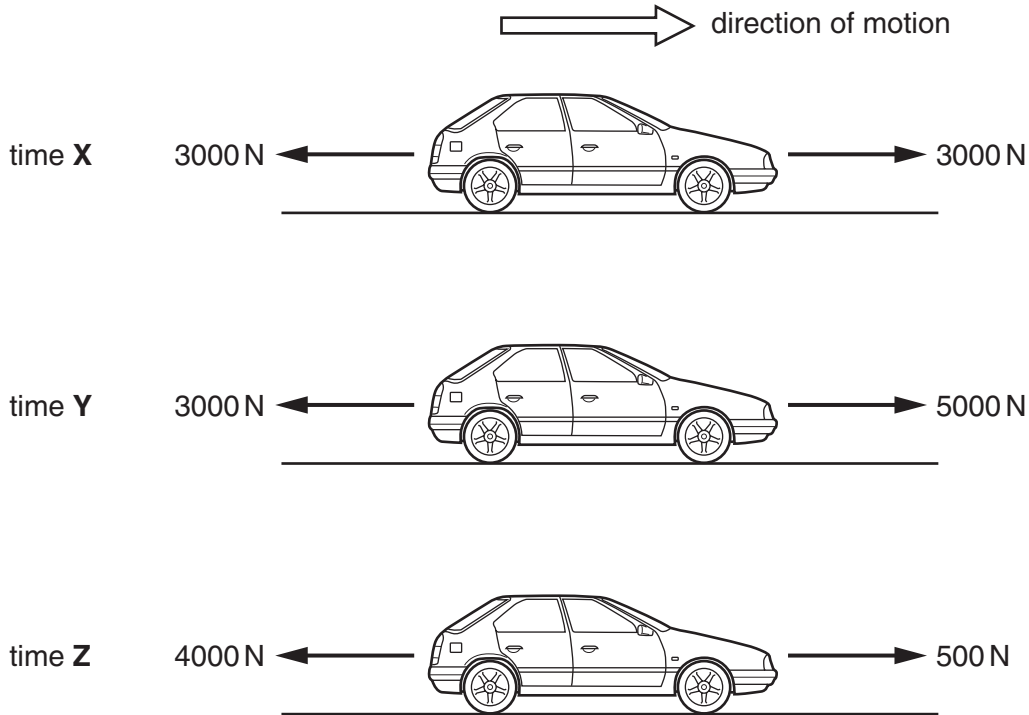

Fig. 3.1

In each case, the car is moving forwards. The mass of the car is 1000 kg.

- (a) State the name of **one** of the forces that is acting in the opposite direction to the motion of the car.

..... [1]

- (b) (i) State whether the speed of the car is changing at time **X**.

Explain your answer.

speed at **X** is

explanation

..... [1]

(ii) State whether the speed of the car at time **Z** is increasing, decreasing or is constant.

Explain your answer.

speed at **Z** is.....

explanation

..... [2]

(c) Calculate the acceleration of the car at time **Y**.

acceleration = m/s² [3]

- 4 Fig. 4.1 shows a lever that is used to lift a heavy object.

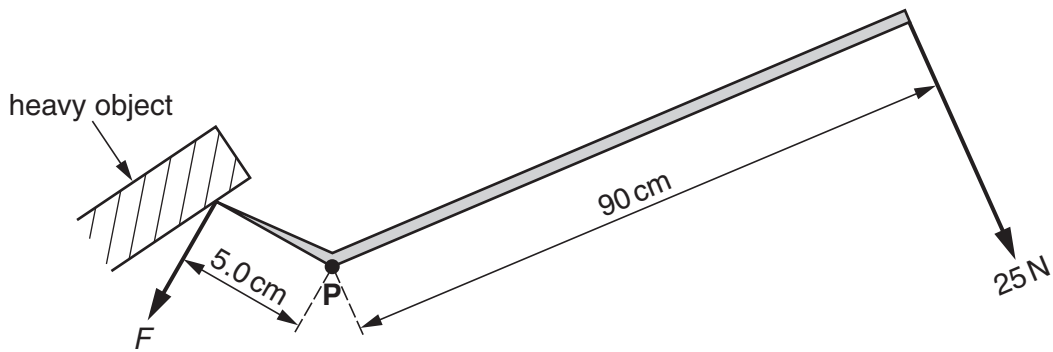

Fig. 4.1

A force of 25 N is applied at a distance of 90 cm from the pivot **P**. The load F on the lever is 5.0 cm from pivot **P**. The directions of the 25 N force and of the load F are both at right-angles to the lever.

- (a) Calculate the load F on the lever.

State the unit.

force = [3]

- (b) The point of application of the force of 25 N is moved through a distance of 0.08 m in the direction of the 25 N force. Calculate the work done on the lever.

State the unit.

work done = [3]

- 5 Fig. 5.1 shows the speed-time graph for the motion of a car.

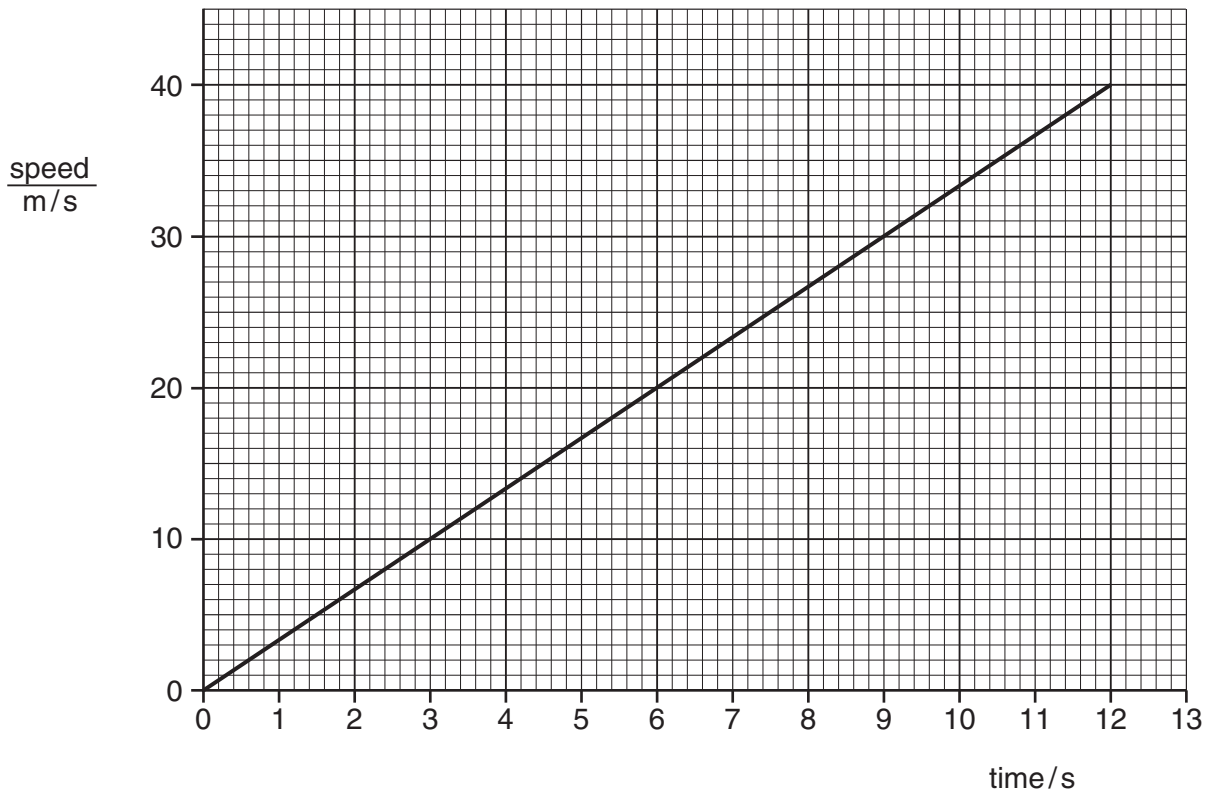

Fig. 5.1

- (a) Calculate the acceleration of the car.

acceleration = m/s² [2]

- (b) Calculate the distance travelled by the car during the first 12 s of its motion.

distance travelled = m [2]

- 6 Fig. 6.1 shows a resistor that is being used to measure the temperature of a liquid. At the lower fixed point, the reading on the voltmeter is 12.0V and the reading on the ammeter is 0.030 A.

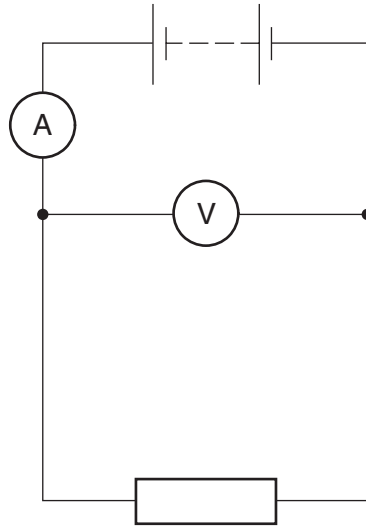

Fig. 6.1

- (a) State what is meant by the *lower fixed point*.

..... [2]

- (b) Show that the resistance of the resistor at the lower fixed point is $400\ \Omega$.

[2]

- (c) The resistance of the resistor is $404\ \Omega$ at the upper fixed point. At an unknown temperature **X**, the resistance is $403\ \Omega$.

Calculate the temperature **X**.

temperature = $^{\circ}\text{C}$ [2]

- 7 Fig. 7.1 shows an electric bell that is suspended in a glass bell-jar. A vacuum pump slowly removes air from the bell-jar.

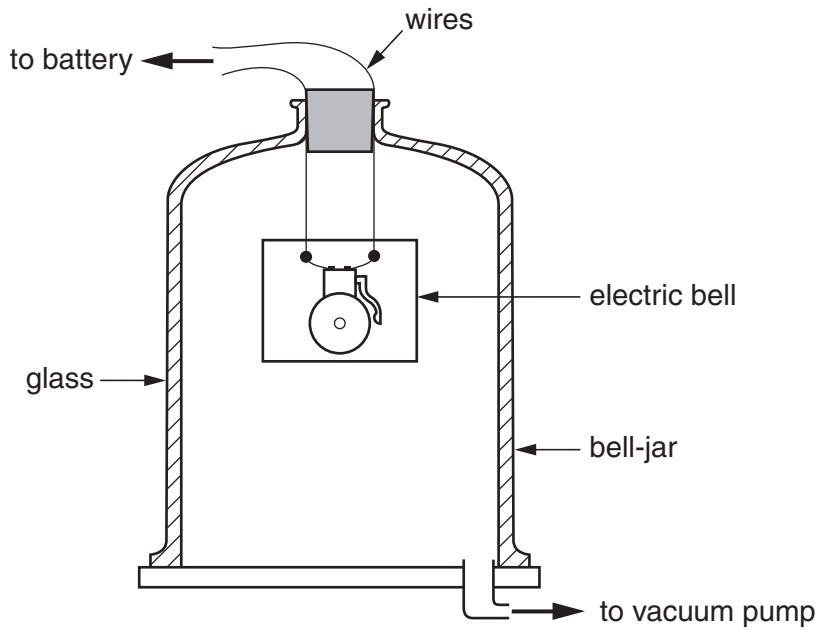

Fig. 7.1

- (a) Sound travels through the air in the bell-jar and then through the glass. State how the speed of the sound changes, if at all, as it passes from the air into the glass.

..... [1]

- (b) State and explain what happens to the sound heard as air is removed from the bell-jar.

.....
 [2]

8 A wave travelling along the surface of water has a wavelength of 8 cm and a frequency of 5 Hz.

(a) State whether the wave is transverse or longitudinal.

Explain your answer.

type of wave

reason

..... [1]

(b) Calculate the speed of the water wave.

speed = cm/s [2]

9 Fig. 9.1 shows two rods of iron inside a coil of wire.

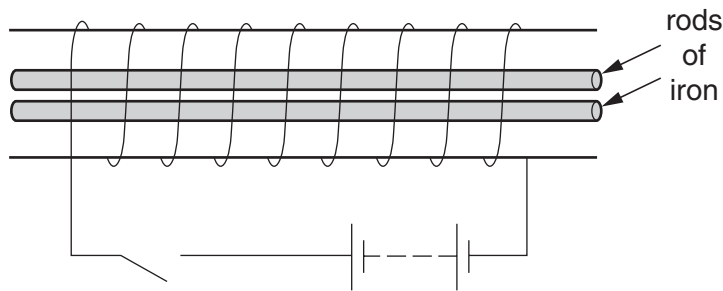

Fig. 9.1

(a) Suggest and explain what happens to the rods when the current in the circuit is switched on.

.....

.....

..... [3]

(b) The current in the coil is now reversed. Suggest and explain what happens to the rods.

.....

.....

..... [2]

10 (a) Iodine-131 ($^{131}_{53}\text{I}$) decays to form an isotope of xenon by emitting beta-particles.

(i) State the nature of a beta-particle.

..... [1]

(ii) State the number of protons in the nucleus of the isotope of xenon that is formed by the decay of iodine-131.

number = [1]

(iii) State the number of electrons in a neutral atom of xenon.

number = [1]

(iv) State the number of neutrons in the nucleus of the isotope of xenon.

number = [1]

(b) State which type of emission from radioactive sources is a component of the electromagnetic spectrum.

..... [1]

Section B

Answer any **two** questions.

Write your answers on the lined paper provided and, if necessary, continue on separate answer paper.

- 11** (a) Describe an experiment to compare the angle of incidence with the angle of reflection for light reflected at a plane mirror. State the result that you would expect. [5]
- (b) Describe the image formed in a plane mirror and state its position. [2]
- (c) Draw a ray diagram to show how a thin converging lens may form a diminished real image. [3]
- 12** (a) Describe an experiment to show that dull black surfaces are better absorbers of infra-red radiation than shiny silver surfaces. [5]
- (b) Describe how thermal energy from the hot water inside a metal tank is lost to the surroundings. [3]
- (c) Explain why double-glazed windows reduce the transfer of thermal energy. [2]
- 13** (a) Draw a diagram of a simple generator and explain how it produces an e.m.f. [5]
- (b) State and explain **two** ways in which the e.m.f. produced in the generator may be increased. [4]
- (c) Suggest why many electrical appliances are earthed. [1]

A series of horizontal dotted lines spanning the width of the page, intended for use as a writing area for the examiner.

A series of horizontal dotted lines for writing, spanning the width of the page.

Lined area for writing with 24 horizontal dotted lines.

A series of horizontal dotted lines for writing.

Permission to reproduce items where third-party owned material protected by copyright is included has been sought and cleared where possible. Every reasonable effort has been made by the publisher (UCLES) to trace copyright holders, but if any items requiring clearance have unwittingly been included, the publisher will be pleased to make amends at the earliest possible opportunity.

University of Cambridge International Examinations is part of the Cambridge Assessment Group. Cambridge Assessment is the brand name of University of Cambridge Local Examinations Syndicate (UCLES), which is itself a department of the University of Cambridge.